

## INSTALLATION INSTRUCTIONS

DESCRIPTION: Accessory Power Connector Kit

PART NUMBER: B4J-H25B0-V0

MODEL: 2018+ Wolverine X2 and X4



### **⚠ WARNING**

Please read and understand these instructions completely before installation to avoid possible injury, or damage to the accessory or vehicle.

### **NOTICE:**

Installation of this kit requires a torque wrench and should be performed by an authorized Yamaha dealer or a qualified mechanic.

### **WARRANTY INFORMATION:**

In the United States, see your Yamaha dealer for a copy of the Yamaha Genuine Parts and Accessories Limited Warranty.

### **DEALER OR INSTALLER:**

These instructions contain important information for future reference and *must* be given to the customer.

## PARTS LIST:

No.	Part Number	Description	Qty
--	<b>B4J-H25B0-V0</b>	Accessory Power Connector Kit	--
①	B4J-H7226-V0	Wire Harness 150mm	5
②	B4J-H2529-V0	Connector	10

\* Part supplied with kit only and not available separately.

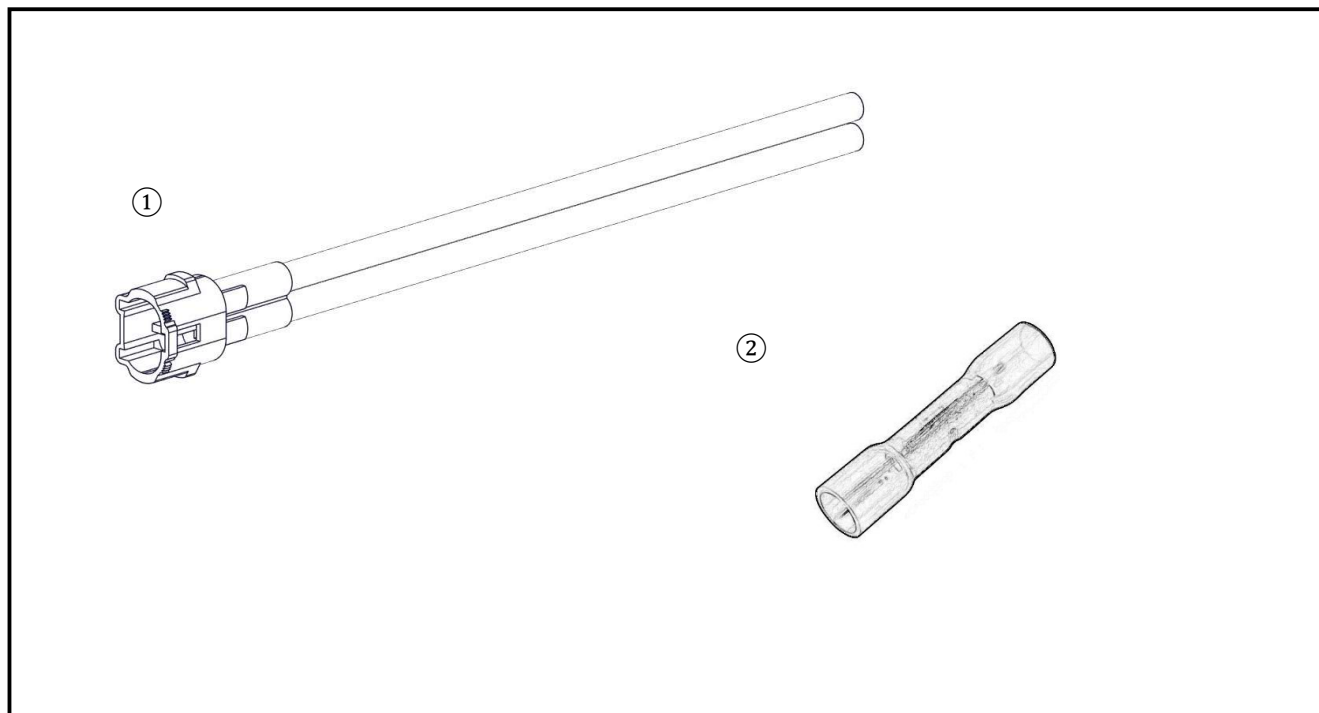

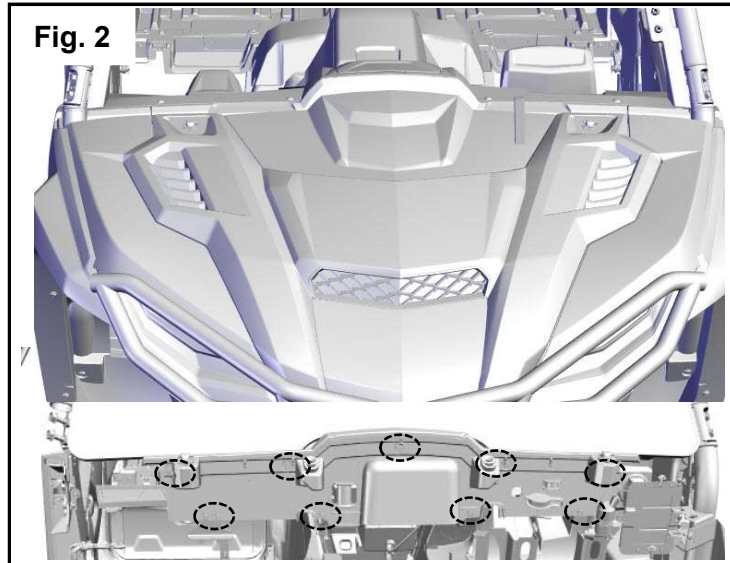
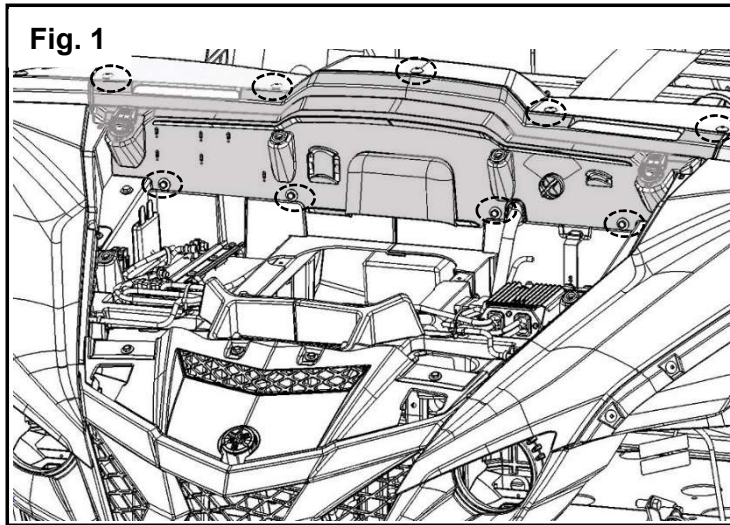

### PREPARATION:

- Place the vehicle on a secure and level surface.
- Set the parking brake.
- Clean the mounting surfaces before beginning installation.

### INSTALLATION:

1. Crimp connect the 12-volt accessory to the ② Connectors and then crimp them to the ① Wire Harness 150mm.
2. Remove the hood and access the inner firewall. Remove the nine bolts that hold the firewall to the hood section. Disconnect the speed key wire harness (if equipped). Retain the stock bolts for reuse. (Fig. 1 and 2)
3. Locate the accessory wire harness and connect the ① Wire Harness 150mm. (Fig. 3)
4. Route the other end as needed. (Fig. 3)
5. Reinstall the inner firewall with the stock bolts. Torque to 3Nm (0.3 m·kg or 2.2 lb·ft).
6. Install the hood back on the vehicle.

**Specification: Total of all accessory power connections may not exceed 20 amps.**

### MAINTENANCE:

Periodically, check torque on all hardware. If loose hardware is found, re-torque to specification.

### CARE AND CLEANING:

Clean painted metal parts with a clean soft cloth and mild soap and water solution. Rinse and dry.

### CUSTOMER SERVICE:

For further information see your Yamaha dealer.

**ESTIMATED TIME TO INSTALL: N/A HRS.**